

## Specification of: RQM F3-3135-BI-QG-M

### Direct driven high-performance centrifugal fan RQM MultiEvo with Ultra-Premium permanent magnet motor at the efficiency level of the efficiency class IE5 and integrated drive (VFD).

Complete assembly module with highest system efficiency, specifically designed and optimized for use in air handling units. Multi volute flow guiding device of galvanized sheet steel to increase pressure and static fan efficiency. Newly developed high performance impeller with optimized shape and highest efficiency, comprising six backward curved hollow section true aerofoil blades with real turbulence profile and rounded, inclined blade leading edges from impeller shroud to back plate, for optimal impact over the entire width of the blade. Aerodynamically and acoustically optimized with highest static efficiencies. Impeller made of high tensile sheet steel in an automated manufacturing process, robotic welding, degreased, iron phosphated and coated with a high quality epoxy-polyester mixed powder, fastened with a clamping bush to the shaft of the foot motor, balanced statically and dynamically according to DIN ISO 21940-11. System inlet cone made of galvanized sheet steel for optimal inflow to the impeller, equipped with flow measuring device IMV as a standard feature. Ultra premium motor with highly efficient permanent magnet technology and efficiency class IE5. Motor magnets without rare earth metals. Integrated drive (VFD), mounted on the motor support plate, optimally coordinated with the high performance impeller. Drive (VFD) preprogrammed, immediately ready for operation with signal 0 to 10 V. With Modbus interface. No shielded connection cable necessary. The drive system is 100 % speed controllable. Prepared for easy floor, wall or ceiling mounting on inlet side. For operation with any arrangement of the axes. Performance data to DIN 24166 Class 1 (BS 848 Class "A")



## Technical data of the fan: RQM F3-3135-BI-QG-M

[fulfills the ErP requirements 2015](#)

Description	Value Dimension
<b>Specified duty point</b>	
<b>Design duty point</b>	
Installation acc. DIN 24163 Part 1	A
Reference density (Rho1)	1.20 kg/m <sup>3</sup>
Medium temperature (t)	20 C
Fan weight	39 kg
<b>Feed data</b>	
Main's frequency (f <sub>N</sub> )	50/60 Hz
Voltage (U <sub>N</sub> )	3~ 380-480 V
<b>Rated motor data</b>	
Phases-Voltage-Frequency	3~400-188 V-Hz
Frame size-No of poles:	150-45 / IE5-10
Power (P <sub>N</sub> )	2.1 kW
Speed (n <sub>N</sub> )	2250 min <sup>-1</sup>
Current (I <sub>N</sub> )	5,0 A
<b>operational limits</b>	
Max. fan speed (n <sub>vmax</sub> )	2950 min <sup>-1</sup>
Max. operating frequency (f <sub>max</sub> )	246 Hz
Temperature range for conveying medium (t <sub>min</sub> ...t <sub>max</sub> )	-20...40 C
<b>ErP-Data at best efficiency and density - kg/m<sup>3</sup></b>	
measurement- / efficiency category	A / static
design status of VSD	VSD is integrated
overall efficiency (ETA <sub>opt</sub> )	78.6 %
achieved efficiency grade (N <sub>ist</sub> )	86.5
required efficiency grade in 2013 / 2015 (N)	58 / 61
Air flow rate (V <sub>opt</sub> )	4094 m <sup>3</sup> /h
pressure rise (dp <sub>opt</sub> )	1234 Pa
Fan speed (n <sub>vopt</sub> )	2950 min <sup>-1</sup>
motor power input (P <sub>1opt</sub> )	1.79 kW
specific ratio (d <sub>dopt</sub> )	1.012

## Fan curve to RQM F3-3135-BI-QG-M

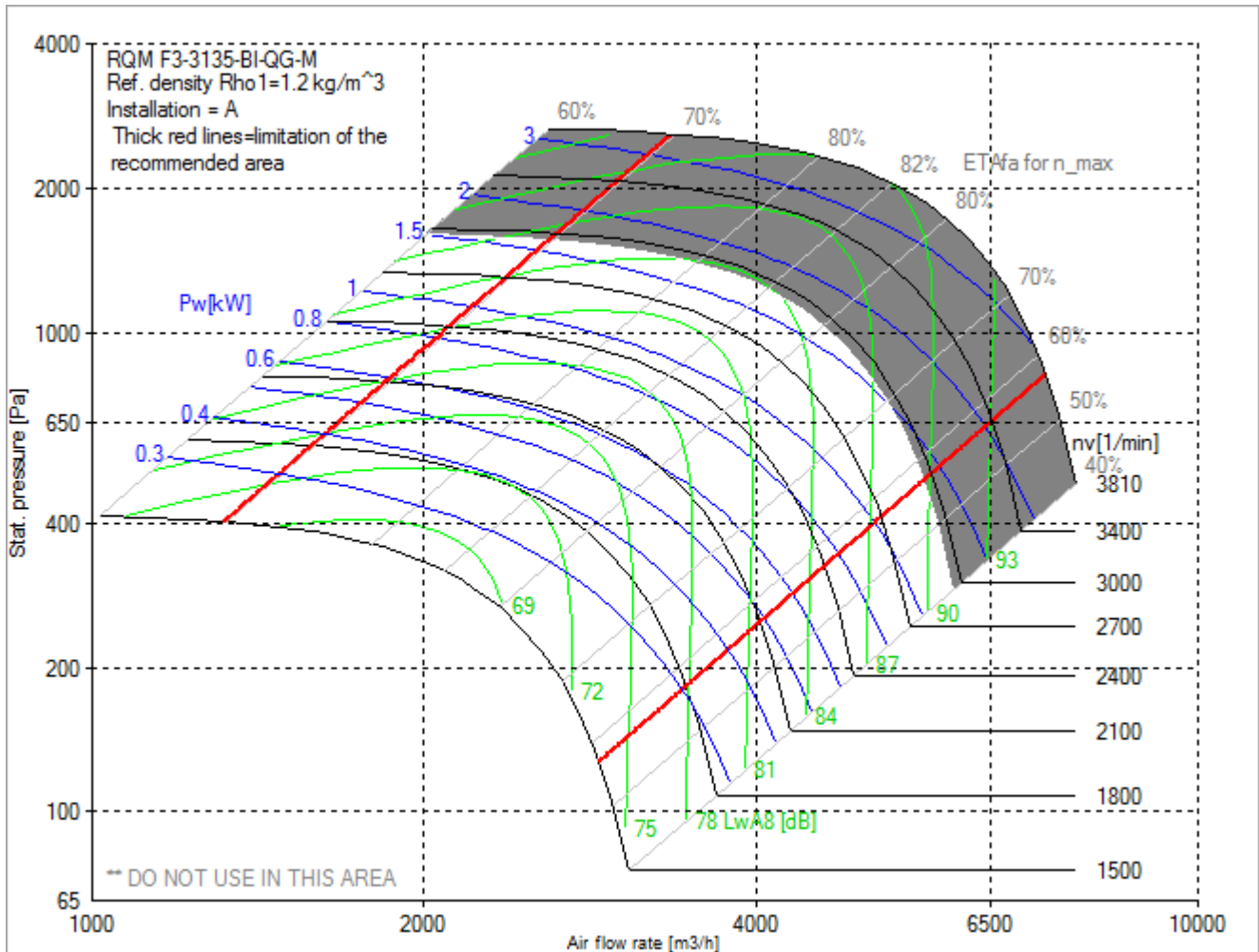

## Dimensions to RQM F3-3135-BI-QG-M

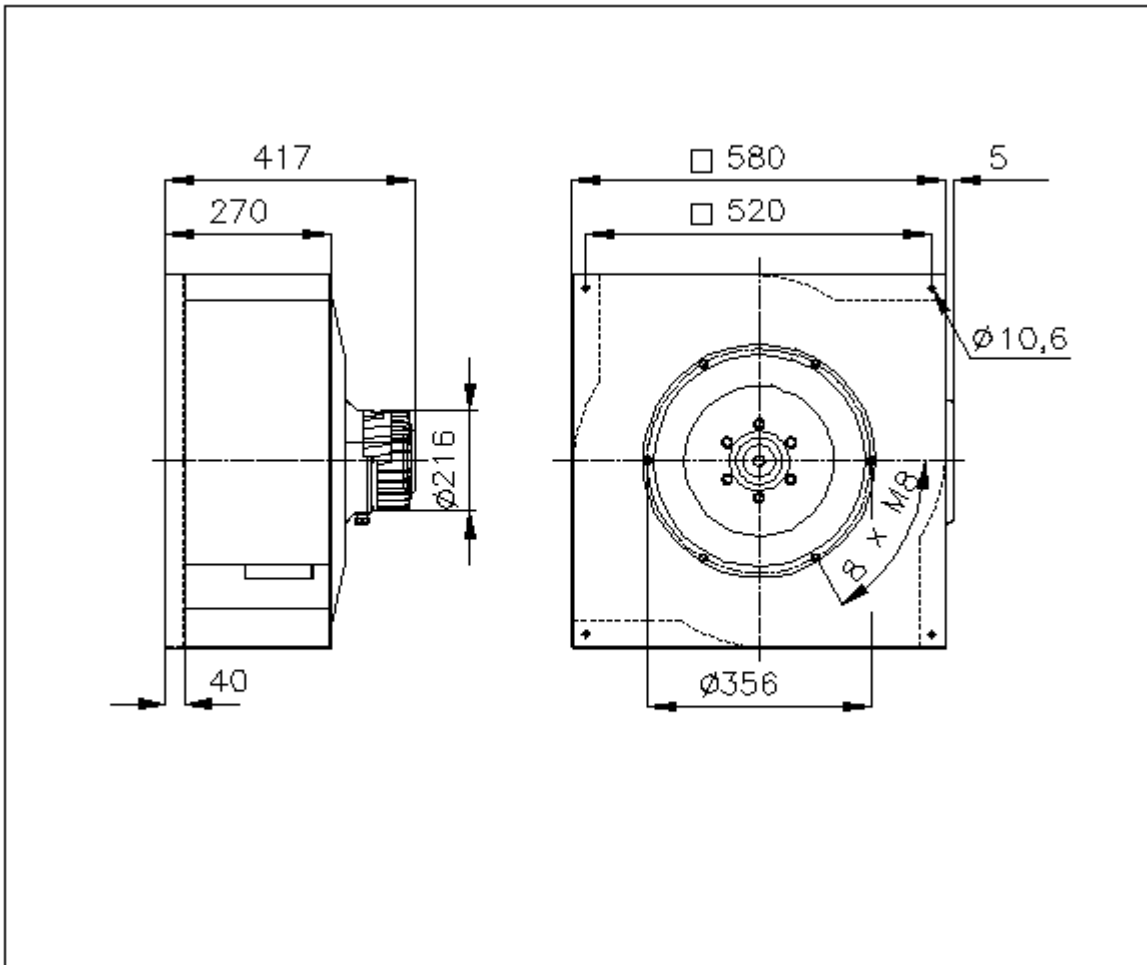

Rotation: RD  
Handing: 90

## Wiring diagram of the fan RQM F3-3135-BI-QG-M

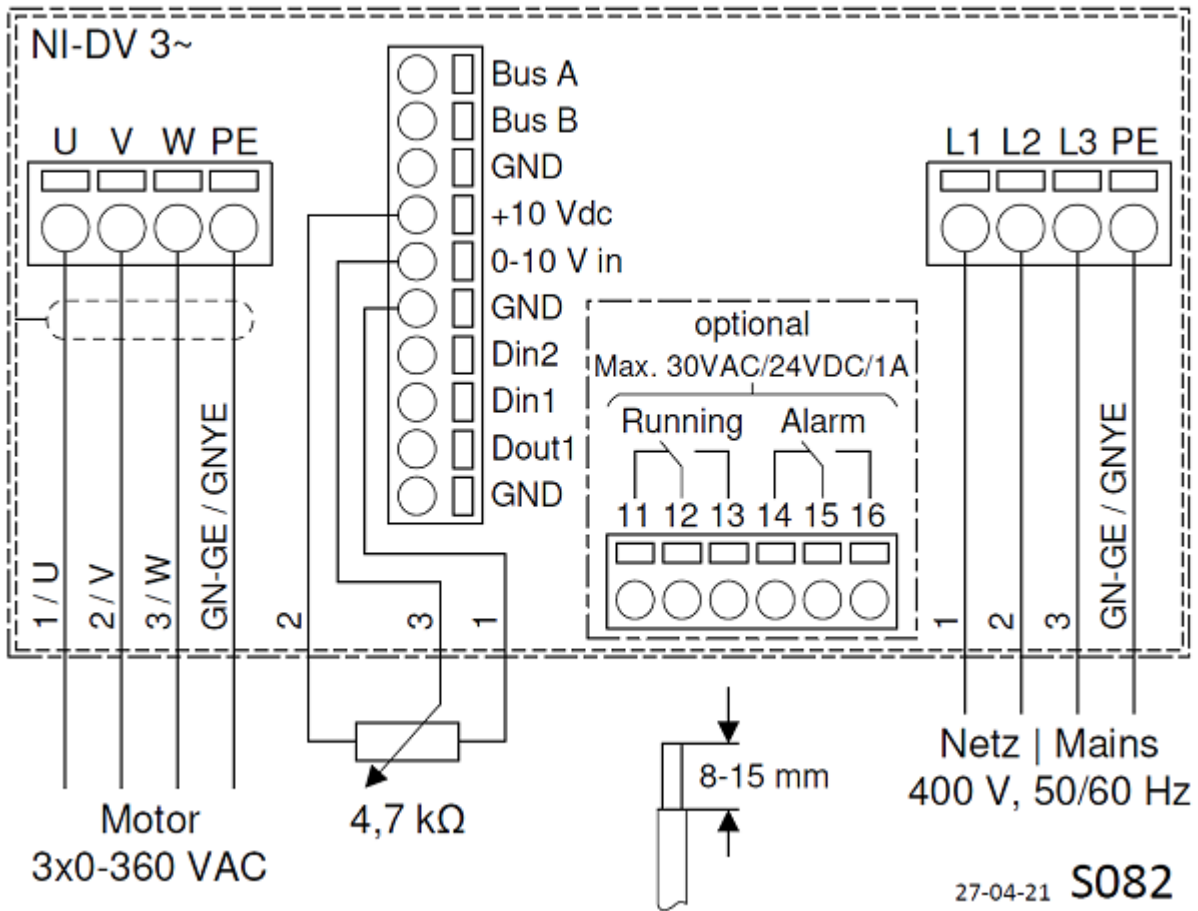

Wiring diagram for connection to: [mains - VSD - motor](#)  
 Rotation: [RD](#)